

Spec Sheet

Rally

Vehicle: G4K	Date: 17.09.2001				
Engine-No.:	ECU-Issue :				
Driver:	Event: Asphalt soll				
	Front Axle			Rear Axle	
Roll-centre pos.	Vo: unten, hi oben			---	
Spring (N/mm or type)	250/60/80			250/60/60	
Helper spring (N/mm or type)	60/60/2			60/60/2	
Damper type	G4KAV Set T35 190			G4KAH Set H8 205	
Damper settings (R/B – low-high)	12/	12-18	12/	12-18	6/ 5-10 6/ 5-10
Bump stop Ø/length	40/22		40/22		40/10 40/10
Steering spacer (mm)	10/61 Hub				
Anti-Roll bar (D=mm)	30x1 DF breit			DF lang Stahl	
ARB blade Position	Hart	Soft	Med soft	Med soft	
Ride height (see sketch)	175		175		185 185
Spring length (incl. helper)	350		350		375 375
Bumpsteer spacer (s. sketch)	21,6/21,6 innen kurz				
Kingpin length (s. sketch)	29mm				
Top mount position (s. sketch)	Außen 1		Außen 1		
Castor (°)	6°45'		6°45'		
Camber (°)	-2°15'		-2°15'		-2°30' -2°30'
Camber spacer	8,13		8,13		B12 B12
Track (mm)	0				+2,5
Steering rod length	320				
A-arm length	B-E1 450 / E2-E3 430				
Brakes					
Brake disc	355x32mm			280x9,6mm	
Brake caliper	Alcon 6 Kolben Wassergek.			Alcon 4 Kolben vorne	
Brake master cylinders	0,75			0,875	
Hand brake master cylinder	---			0,625	
Brake pad type	PF83			PF83	
Clutch					
Clutch drive plate	Starr 450Nm				
Clutch master cylinder	0,75				
Wheels					
Wheels	8"x18"			8"x18"	
Tyre size	225/650x18"			225/650x18"	
Tyre pressures	1,8			1,8	
Gearbox					
Final drive	4,46				
Differential	<input checked="" type="checkbox"/> VC <input type="checkbox"/> ZF GSP				
Ramp angle	Load 20			Off-Load 80	
Friction faces (per side)	6				
Preload (Nm) / End float	70Nm				
Weight [kg]	FL	FR	RL	RR	
Various:					

Spec Sheet

Rally

Delete if not applicable

Ride height front

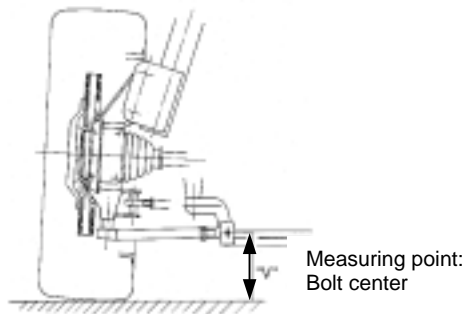

Ride height rear

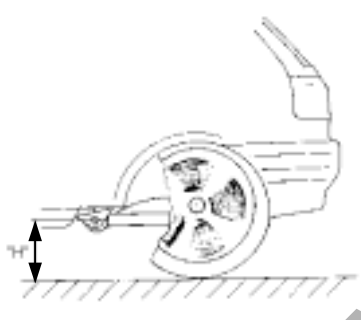

Tie rod position

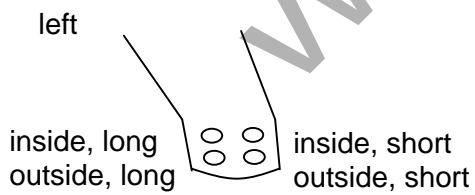

King Pin

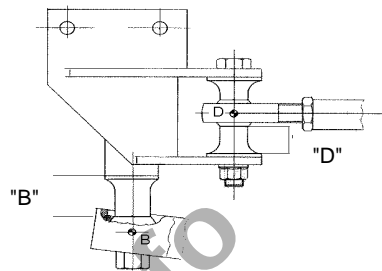

Position of mounting plate

Example: Wheel arch, front / right

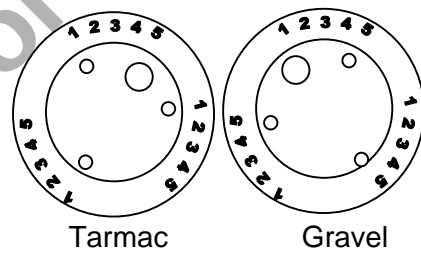

Tie rod length

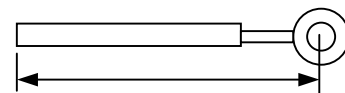

Wishbone length

